

Ultrahigh-vacuum, high pressure and temperature infrared-ultraviolet-visible spectrophotometer cell

E. Gallei* and E. Schadow

Institut für Chemische Technologie, TH Darmstadt, 61 Darmstadt, Hochschulstr., West Germany

(Received 24 July 1974; and in final form, 26 August 1974)

An ir-uv-visible spectrophotometer cell for examining gas-solid interactions at elevated temperatures up to 600°C and high pressures or ultrahigh vacuum has been designed and fabricated. The cell is employed for characterization of reactive catalyst species and reaction intermediates which exist only at conditions above ambient. The pressure maxima are limited by the window material which in turn is determined by the spectral range to be investigated. A compact design out of one piece and large windows permit the use of the cell interchangeably among a variety of commercially available ir and uv-visible spectrophotometers. The design of the cell has been reported. In addition two specific applications of the cell to high vacuum and high pressures at elevated temperature (200°C) are described.

INTRODUCTION

Spectroscopic methods are a powerful tool for the investigation of chemical reactions on the surfaces of various catalysts. The most common technique is the transmission method. In this method the catalyst samples (e.g., small particle size metal oxides) are pressed to transparent discs¹ or placed between light-transmitting windows.^{2,3} Among the spectroscopic methods, ir spectroscopy is most commonly used for the study of chemical reactions on catalyst surfaces. It is especially useful for showing the existence of transient intermediates on the catalyst. Such intermediates have a high influence on the distribution and concentration of the final products. For a successful study of surface reactions, it is necessary first to know the exact chemical composition of the surface. Therefore we have to remove the surface impurities by a ultrahigh vacuum treatment at high temperatures.

However, most of the commercially important reactions must be performed at high pressures and temperatures to achieve desirable reaction rates and equilibria. When such superambient conditions are applied, the structure and even the existence of transient intermediates are usually not directly observed but inferred from the product distribution.

It is preferable if one can base conclusions concerning the reaction mechanism on observations made under reaction conditions, e.g., high pressure or high vacuum and high temperatures. Therefore, in the present paper, a spectrophotometer cell is described by which it is possible to record spectra during catalytic gas-solid reactions under technological conditions.

THE SPECTROPHOTOMETER CELL

Many spectrophotometer cells have been reported for uv-visible and ir studies for very high vacuum or high pressure at high temperatures⁴⁻⁹; but no cell is reported which can be used for both high pressure and high vacuum at high temperatures. One of the major difficulties (window-to-metal seal) which have hindered the construction of these cells in the past has been discussed by Tinker and Morris.¹⁰ But their cell is applicable only to spectroscopic studies on liquids at high pressures and temperatures. The cell described here incorporates certain features not found in the numerous papers about spectrophotometer cells discussed in literature. Specific differences are:

(i) The cell body is constructed out of one piece (no welding) and employs only homebuilt Conflat flanges as

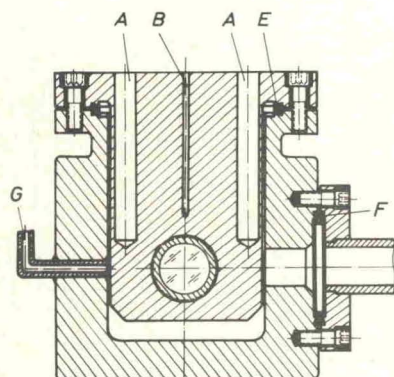

FIG. 1. Cross section view of the cell.

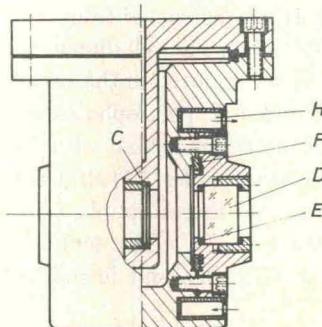

FIG. 2. Cross section view of the window to metal seal.

APR 21 1975

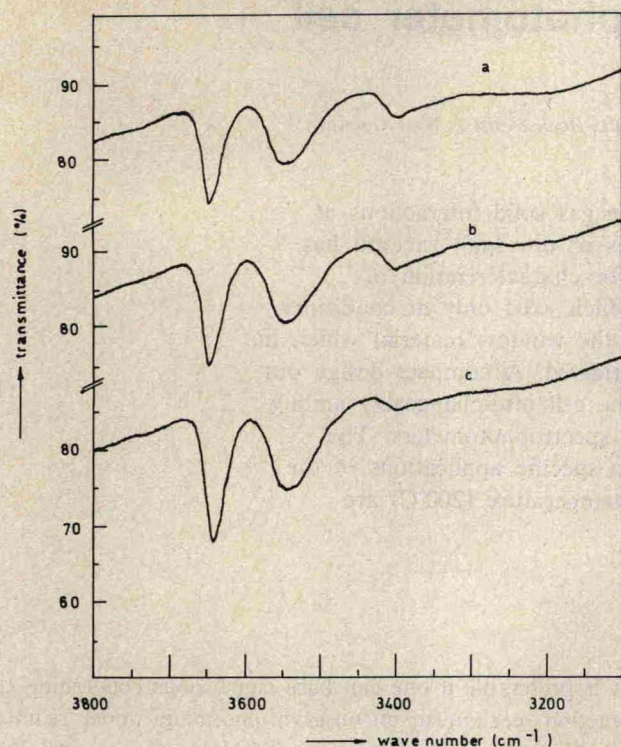

FIG. 3. Infrared spectra of partially decaionized $\text{NH}_4\text{-Y}$ zeolite recorded at 200°C and various pressures: (a) $p < 10^{-4}$ Torr; (b) $p < 10^{-6}$ Torr; (c) $p < 10^{-8}$ Torr.

seals. Therefore it is possible to use the cell for ultrahigh-vacuum studies.

(ii) To escape interference from gas atmosphere, the path length in the cell is kept very small by the rectangular shape.

(iii) Very efficient cooling jackets keep the windows at fairly low temperatures ($\sim 50^\circ\text{C}$), even when the sample reaches temperatures of 600°C .

(iv) The cell can be used for both high pressure and ultrahigh vacuum studies at high temperatures.

(v) The sample, heaters, and thermocouple can be exchanged without removing the cell from the sample compartment of the spectrophotometer. (Heaters, thermocouple, and sample holder are attached to the lid.)

DESIGN AND CONSTRUCTION OF THE CELL

A cross section of the spectrophotometer cell for high pressure, ultrahigh vacuum measurements at high temperatures is shown in Figs. 1 and 2. It is constructed from AISI 316, a corrosion-resistant stainless steel. The cell dimensions are $115 \times 110 \times 70$ mm and it can be mounted in the sample compartment of a commercial infrared spectrophotometer (e.g., Perkin Elmer type 325). The cell is heated with two 315 W tubular heaters inserted in the holes (A) drilled in the upper flange. A Chromel/Alumel thermocouple (B) is used to control the temperature to $\pm 2^\circ\text{C}$. The sample is sprinkled between two transparent plates and introduced into the sample cavity (C).

The cell body and the flanges can withstand pressures of approximately 200 atm at 600°C , but the mechanical

strength of the window material is the critical point; 15 mm thick CaF_2 windows (D) of 25 mm diam were used for high pressure and high vacuum measurements. Commercially available 7 cm Conflat flanges with soldered CaF_2 windows (manufactured by Harshaw Co., U.S.A.) were employed for ultrahigh vacuum experiments. To keep the windows at fairly low temperatures ($\sim 50^\circ\text{C}$), very effective cooling jackets (H) were used.

The useful spectral range for CaF_2 is from the visible to approximately 1400 cm^{-1} . The maximum pressure the windows will withstand is related to the thickness and unsupported diameter D (cm) of the window by the relation of Morris and Tinker⁹: $T/D = 1.06 (p/F_a)^{0.5}$, where T is the window thickness (cm) and p (atm) is the maximum pressure the window will withstand; F_a is the apparent elastic limits (atm). The authors propose a safety factor of 4; with $F_a = 360$ atm for calcium fluoride at 25°C the windows in our cell should withstand 180 atm. But no systematic studies have been performed to determine the rupture point of CaF_2 windows. We were able to use the cell up to 80 atm and 600°C without complications.

As seals, Viton O-rings (E) and copper gaskets (F) were used during the high vacuum and high pressure experiments. For ultrahigh vacuum studies copper gaskets were employed exclusively. Both had to be replaced periodically to avoid leakage.

By opening the valve at the outlet (G), the cell can be used as flow-through reactor.

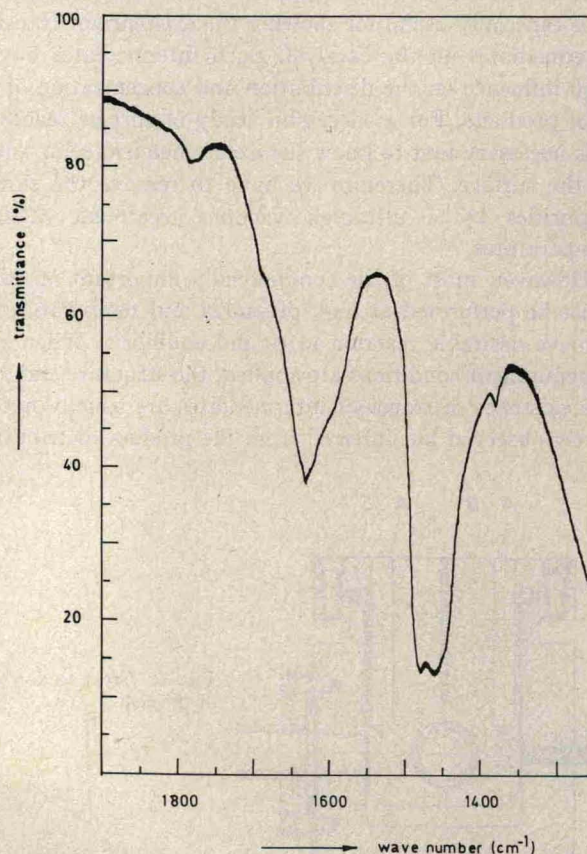

FIG. 4. Infrared spectrum of CaY zeolite after interaction with carbon dioxide at 200°C for 15 min.